

Belvac Production Machinery Technical Bulletin

Information for Customers Operating and Maintaining Belvac Machines

ISSUE 3, VOLUME 11, APRIL 2008

Trimmer Spindle Assembly Bearing Preload Upgrade

Original preloading of the deep groove radial bearings on the spindle assembly was accomplished by torquing a split threaded locking collar and verifying 2 to 3 "spins" of the outer spindle relative to the shaft. (Refer to Figure 2.) The bearings could become over-torqued when the split collar was clamped securely: the "spin" method was subjective.

Three issues could take place with an improper bearing preload setup on the spindle shaft:

1. As the bearings wear over time a loss of preload results, creating excessive end-float.
2. If the bearings were set up with too much preload they wear prematurely.
3. An insufficient amount of preload causes unacceptable end-float.

To resolve these setup difficulties and premature bearing longevity, Belvac designed and field-tested a self-compensating bearing preload. (Refer to Figure 1.) This design preloads the bearing inner races with a set of wavy washer springs. As the bearings wear over time, the springs maintain consistent preload and shaft position integrity. Discrete setup instructions are provided on the assembly prints as well as in the trimmer manual.

Belvac offers upgrade kits for existing CC92/93/95 spindle assemblies on a per spindle basis, by ordering kit #121160-CC93. The kit consists of quantity (3) wavy washers, (1) modified split locking collar, and instruction drawing. When upgrading, it is recommended both bearings (C20014), item #461, be replaced.

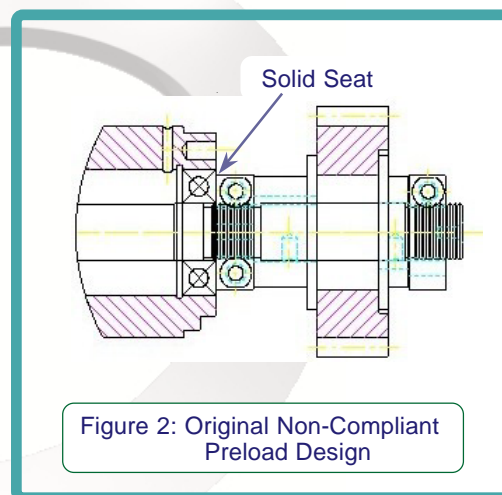
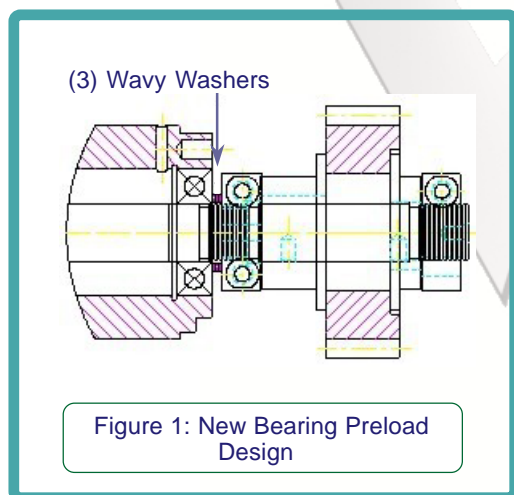

The new design will be standard on all BELVAC trimmers effective July 1, 2008.

KIT INFORMATION:

UPGRADE KIT #121160-CC93

ORDER QUANTITY (1) KIT PER SPINDLE ASSEMBLY

Contact Belvac Sales or Service Representatives for additional information.

Belvac Production Machinery, Inc.

237 Graves Mill Road, Lynchburg, Va. 24502 USA
info@belvac.com

Tel. (434) 239-0358 Fax (434) 239-1964
http://www.belvac.com