



# Belvac Production Machinery Technical Bulletin

Information for Customers Operating & Maintaining Belvac Machines

ISSUE 4, VOLUME 15, OCTOBER 2012

## HD Cartridge Grease Changes

Belvac's HD Cartridge design was designed to be greased and serviced with the cartridge installed on the trimmer. Customer feedback regarding change in axial knife clearance after regreasing has caused concern. Examination has shown grease applied too liberally or too quickly permeates the shim pack causing the lower arm to move axially. As the grease migrates out from between the shims, the lower arm is allowed to float, causing fluctuation in the knife gap. If the lower arm is greased in a slow, controlled fashion, this condition does not occur. Unfortunately most maintainers are not familiar enough with the cartridge and cause this problem to occur.

Belvac's solution to this problem is to remove the re-grease capability of the lower arm on the trimmer by removing the specific grease fitting. Regreasing will be relegating this to the tool room during yearly maintenance, by hand packing the respective needle bearings. To facilitate bearing life in production, two changes are taking place:

1. Needle bearings in the lower arm are being changed to sealed and/or closed end bearings.
2. Grease used in the cartridge is being changed from Exxon Ronex MP NGLI-II to Mobilith SHC PM460 as used in Belvac's EMC cartridges. This grease is formulated to prevent wash-out, and is more resistant to bodymaker coolants.

Refer to the lower shaft assembly below for part changes by item number and description.

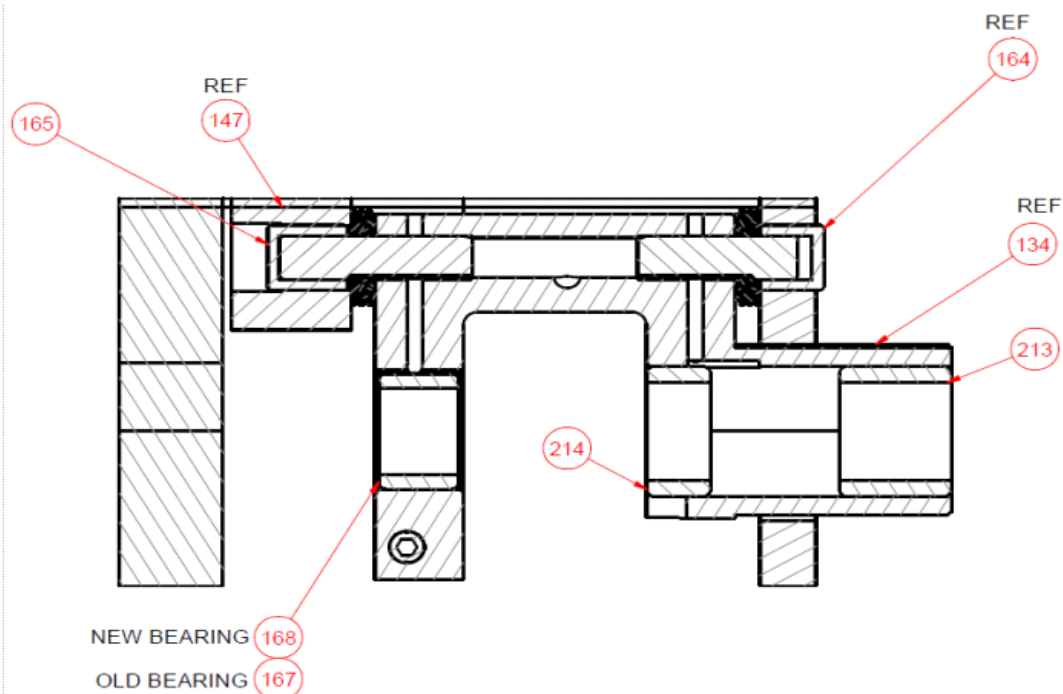



# Belvac Production Machinery Technical Bulletin

Information for Customers Operating & Maintaining Belvac Machines

ISSUE 4, VOLUME 15, OCTOBER 2012

The following parts must be changed:

Item Number	Old Part Number	New Part Number	Description	Qty/ Lower Arm
214	C20029	C101547	Needle Bearing	1
213	101001-CC52	C20035	Needle Bearing	1
168/167	C20030	C101555	Needle Bearing	1
165	C20024	C101552	Needle Bearing	1
208	H17647	H18735	Pipe Plug	1

When performing yearly maintenance on HD trimmer cartridges, ensure you have sufficient stock on the changed needle bearings, in addition to the standard maintenance parts.