



Belvac Production Machinery Technical Bulletin

Information for Customers Operating & Maintaining Belvac Machines

ISSUE 3, VOLUME 16, MAY 2013

MODEL 595/590 REFORMER/REPROFILER AND LIGHT TESTER FACE SEAL MANIFOLD UPGRADE

In 2002, Belvac introduced the Necker Face Seal Manifold (FSM) (Reference Technical Bulletin Issue 01, Volume 5) enabling customers to significantly reduce air consumption between 30% - 50% as compared to the original Lift-Off air manifold design. This design comes standard with a full three year manufacturer's warranty (free of design defects, workmanship, or material, when assembly is subjected to normal conditions and installed properly).

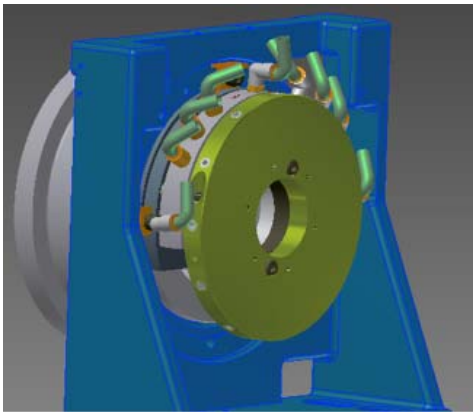

Fixed Base Manifold

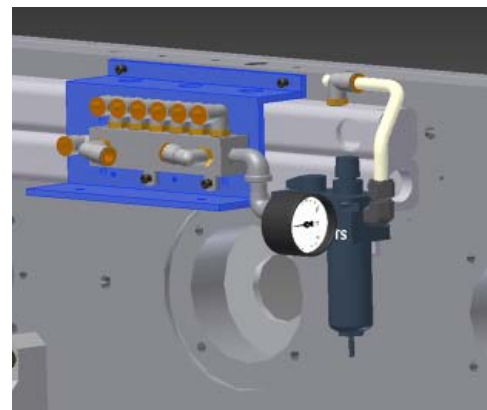

Fixed Base Air Distribution

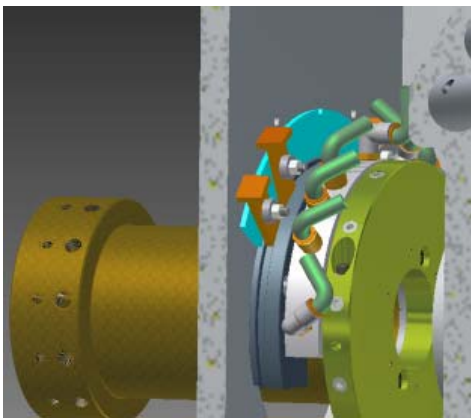

Modular Base Manifold

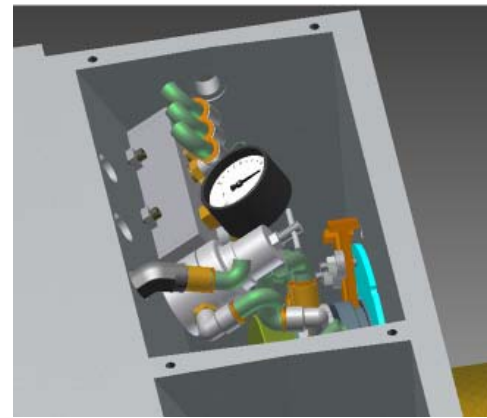

Modular Base Air Distribution



Belvac Production Machinery Technical Bulletin

Information for Customers Operating & Maintaining Belvac Machines

ISSUE 3, VOLUME 16, MAY 2013

Belvac extended this design to include both Reformer/Reprofiler and Light Testers on Modular Machinery as well as Fixed Base machinery. Similar to the Necker Face Seal Manifold, design features of the Reformer and Light Tester manifolds include:

- Regulated supply air to fine tune setup:
 - Reformer/Reprofiler Pressure: 5-10 psig (34.5 – 69 KPa)
 - Light Tester Pressure: 5-8 psig (34.5 – 55.1 KPa)
- May be directly retro-fitted to 595 Non-K, K, and SK model Reformer/Reprofiler & Light Tester turrets
- Floating pistons accommodate shaft adjustments
- Manifold plate is piloted to the gear side cam support for accurate location
- Closed loop piston priming from main air supply
- Adjustable timing
- HyComp lined split rotor for long life and ease of maintenance/installation

Face Seal Manifold Retrofit Kits may be ordered as follows:

TURRET TYPE	FACE SEAL MANIFOLD UPGRADE KITS					
	<i>Non-Offset Necker Tin Line (Ref. 1.812 or 1.937 Die Length)</i>					
	NORMAL ROTATION			REVERSE ROTATION		
	QC	Non-QC		QC	Non-QC	
	QC Modular	Fixed Base <i>(See Note-1)</i>	Fixed Base <i>(See Note-1)</i>	QC Modular	Fixed Base <i>(See Note-1)</i>	Fixed Base <i>(See Note-1)</i>
Reformer Reprofiler	104205-UPGRADE	104214-QC-UPGRADE	104214-UPGRADE	104209-UPGRADE	104213-QC-UPGRADE	104213-UPGRADE
Light Tester	104205-UPGRADE	104212-UPGRADE		104209-UPGRADE	104211-UPGRADE	

Note 1) As seen on the supplied assembly drawings, a solid ring manifold extension must be installed: sufficient assembly time must be allocated as the turret must be disengaged from the drive base for first time assembly.

*For ease of installation, Belvac recommends wrench #104055 is purchased on a per machine basis.

This wrench does not come standard with every kit. Please purchase separately.

Please contact Sales & Service at Belvac or e-mail at info@belvac.com for more information.



237 Graves Mill Road, Lynchburg, Va. 24502 USA

Tel. (434) 239-0358

Fax (434) 239-1964

info@belvac.com

<http://www.belvac.com>